

ROBY JUNIOR 2

Case making machine

Copertinatrice



Max size 540x740 mm



Mechanical speed 250 cycles/h

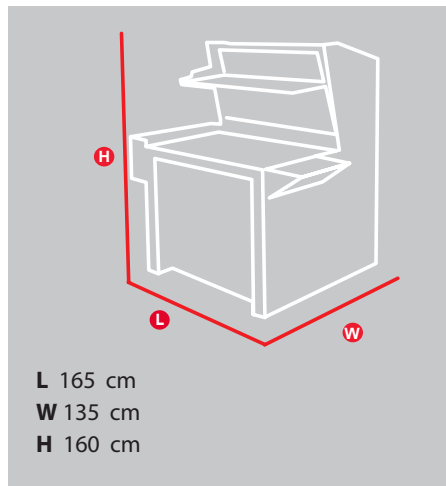

Roby Junior 2 is a compact and versatile semi automatic casemaker with automatic board feeder.

It features:

- gluing unit
- automatic cardboard feeder
- turning-in

Optional

- Photobook device
- Kit for 5-pieces cover (automatic board feeder)
- Kit of 5/8/10 mm spacers
- Extra turning-in and pressing station (Vas)

Roby Junior 2 + Vas

Vas dimension - *Dimensioni Vas:*
135x90xh105 cm



Roby Junior 2 è una copertinatrice semiautomatica, compatta e versatile con alimentatore automatico del cartone.

Caratteristiche:

- unità di incollaggio
- alimentatore automatico del cartone
- rimbocco

Optional

- Dispositivo per album fotografico
- Kit per copertina a 5 pezzi (alimentatore cartone automatico)
- Kit spaziatori da 5/8/10 mm
- Unità extra rimbocco e calandra (Vas)

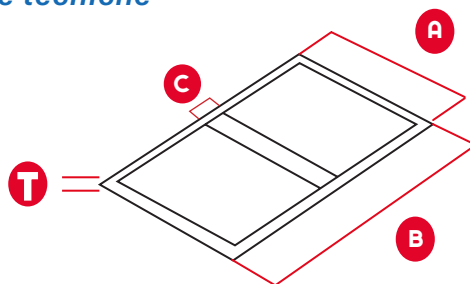

Technical data - *Specifiche tecniche*

Max. covering material size (AxB) <i>Max. formato materiale di rivestimento</i>	540 x 740 mm
Board thickness (T) <i>Spessore del cartone</i>	1,5 - 3 mm
Turn-in <i>Rimbocco</i>	18 - 25 mm
Spine board's thickness <i>Spessore del cartone del corpino</i>	0,8 - 3 mm
Covering material grammage <i>Grammatura materiale di rivestimento</i>	90 - 160 gr/m ²
Type of glue <i>Tipo di colla</i>	usually hot, animal glue; vinyl glue is also possible <i>a caldo, colla animale; possibile utilizzo di colla vinilica</i>
Max. mechanical speed <i>Massima velocità meccanica</i>	250 cycles/h
Standard voltage <i>Voltaggio standard</i>	400 V/50 Hz/Ph 3 (others available upon request)
Rated power <i>Potenza nominale</i>	1,5 kW
Compressed air consumption <i>Consumo di aria compressa</i>	150 l/min at 6 bar
Machine dimension (LxWxH) <i>Dimensioni macchina</i>	165 x 135 x 160 cm
Weight <i>Peso</i>	280 kg

Manual board feeder- Alimentatore cartone manuale

Max. board size (AxB) <i>Max. dimensione del cartone</i>	500 x 700 mm
Min. board size (AxB) <i>Min. dimensione del cartone</i>	140 x 140 mm
Max. distance between spine and board <i>Max. distanza tra dorso e cartone</i>	8 mm
Min. width of spine (C) <i>Min. larghezza dorso</i>	8 mm

Automatic board feeder- Alimentatore cartone automatico

Max. board size (AxB) <i>Max. dimensione del cartone</i>	400 x 700 mm
Min. board size (AxB) <i>Min. dimensione del cartone</i>	295 x 210 mm
Max. distance between spine and board <i>Max. distanza tra dorso e cartone</i>	10 mm
Min. width of spine (C) <i>Min. larghezza dorso</i>	12,5 mm - 8 mm (with/con optional)

*Technical data can vary without warning - I dati tecnici sono indicativi e possono variare senza preavviso.
Mechanical speed can vary depending on size and material - Le velocità di produzione possono variare in funzione dei formati e dei materiali.